

# XPO RAIL

3 CLIPS/M - 20 KG/M

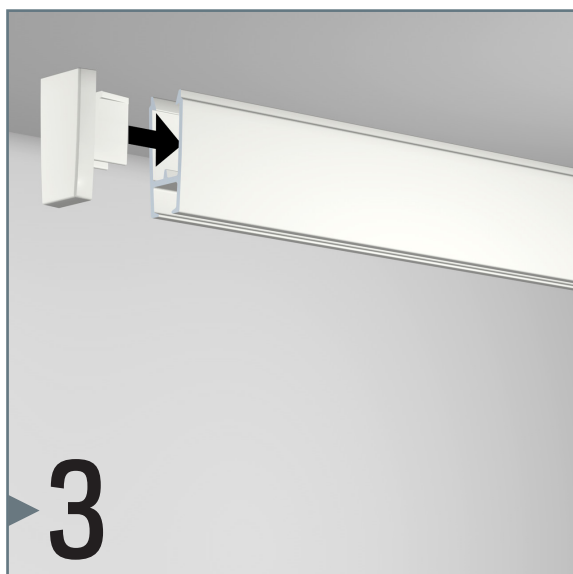

installation movie:

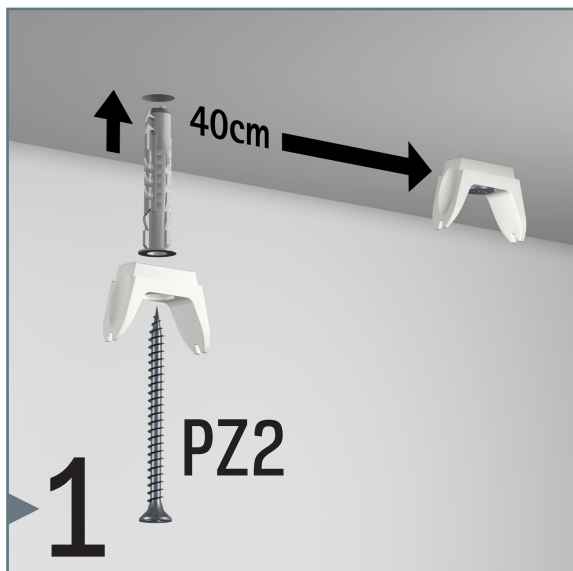
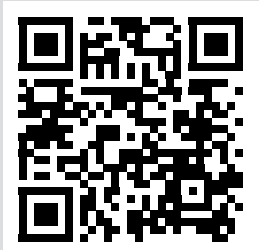

FLEXIBLE  
SAFE  
STRONG

# XPO RAIL

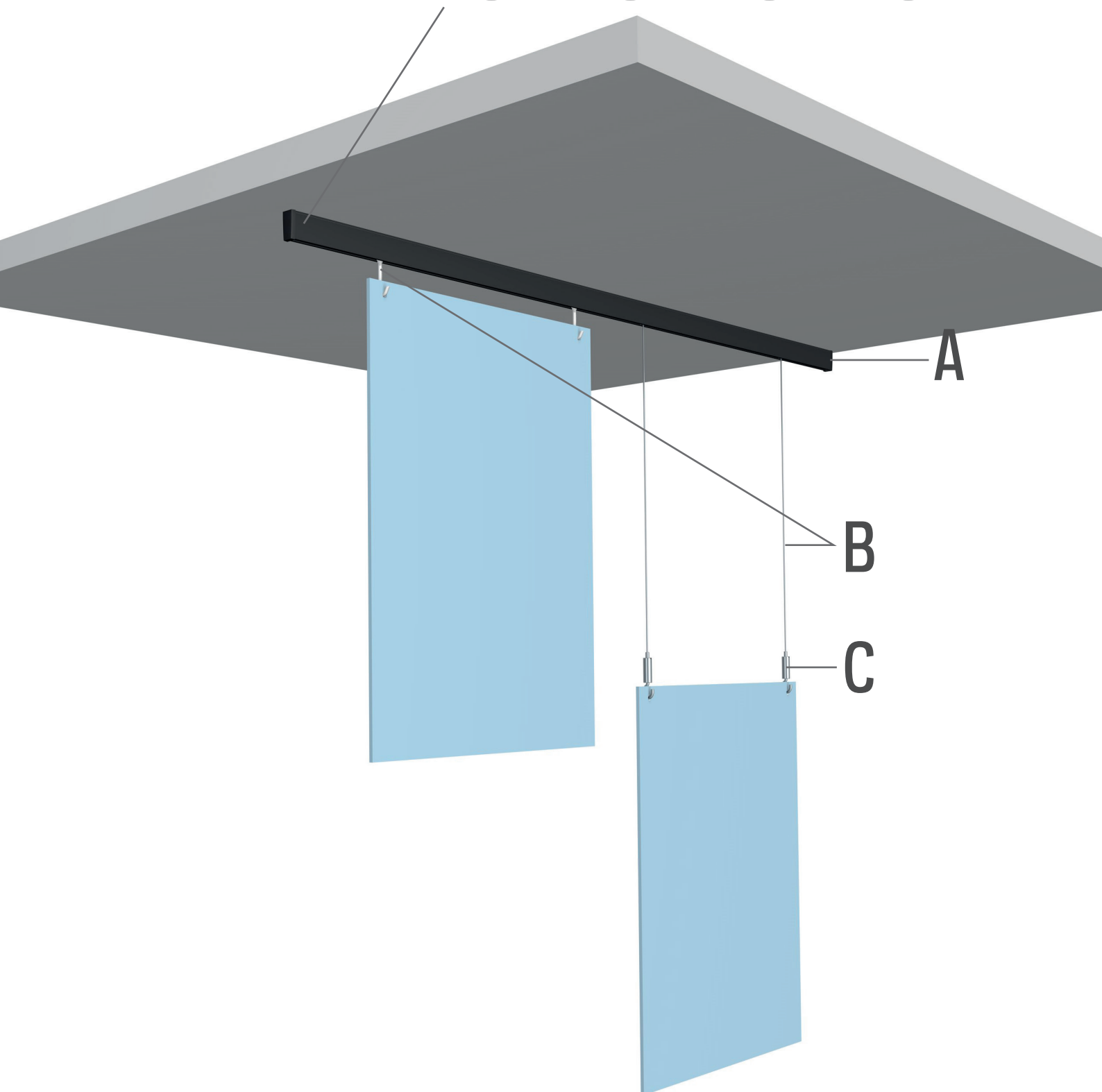
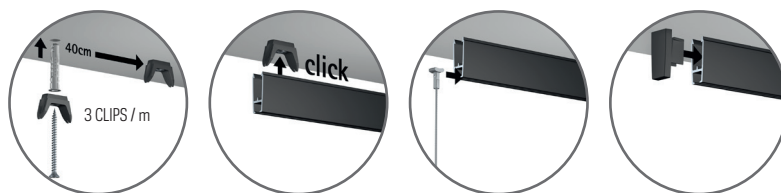

**GETOONDE COMBINATIE:**



- A + B3
- A + B1 + C3

**MOGELIJKE COMBINATIES:**





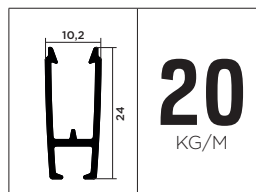

- A + B1/B2 + C1/C2/C3/C4/C5
- A + B3

# XPO RAIL



A

A		
		
XPO RAIL 200 cm ZWART	XPO RAIL 200 cm WIT PRIMER	XPO RAIL 200 cm ALU GEBORSTELD
05.15201	05.15200	05.15202







A						
						
EINDKAP XPO RAIL ZWART	EINDKAP XPO RAIL WIT	CLIP CLICK&CONNECT XPO RAIL	PLUG (Ø 5 mm)	SCHROEF	MONTAGESET XPO RAIL WIT 200 CM	MONTAGESET XPO RAIL ZWART/ALU 200 CM
05.15030	05.15020	05.15010	9.4929	9.4931	5092	5093

B

B1	B2	B3
		
STAALDRAAD + GLIJDER 1,2 mm 200 cm ZWART	STAALDRAAD + GLIJDER 1,2 mm 200 cm VERNIKKELD	TWISTER HOOK
7807.200	7807.210	9.4510

C

C1	C2	C3	C4	C5
				
STAALDRAADHAAK ZELFKLEMMEND 1,2 mm ST01BL	STAALDRAADHAAK ZELFKLEMMEND 1,2 mm ST01NI	STAALDRAADHAAK ZELFKLEMMEND 1,2 mm ST02NI	STAALDRAADHAAK ZELFKLEMMEND 1,2 mm ST03NI	STAALDRAADKLEMMHAAK ZELFKLEMMEND 1,2 mm STC01NI
7807.010	7807.020	7807.030	7807.040	7807.050

## \* INHOUD MONTAGESET



		AANTAL 200 cm
05.15010	CLIP XPO RAIL	6x
9.4931	PLUG FISCHER 5 mm	6x
9.4929	SCHROEF TBV PLUG FISCHER 5 mm	6x
05.15020 / 05.15030	EINDKAP XPO RAIL WIT / ZWART	2x
2639	INSTRUCTIE	1x



# XPO RAIL VERLAAGD HANGEND

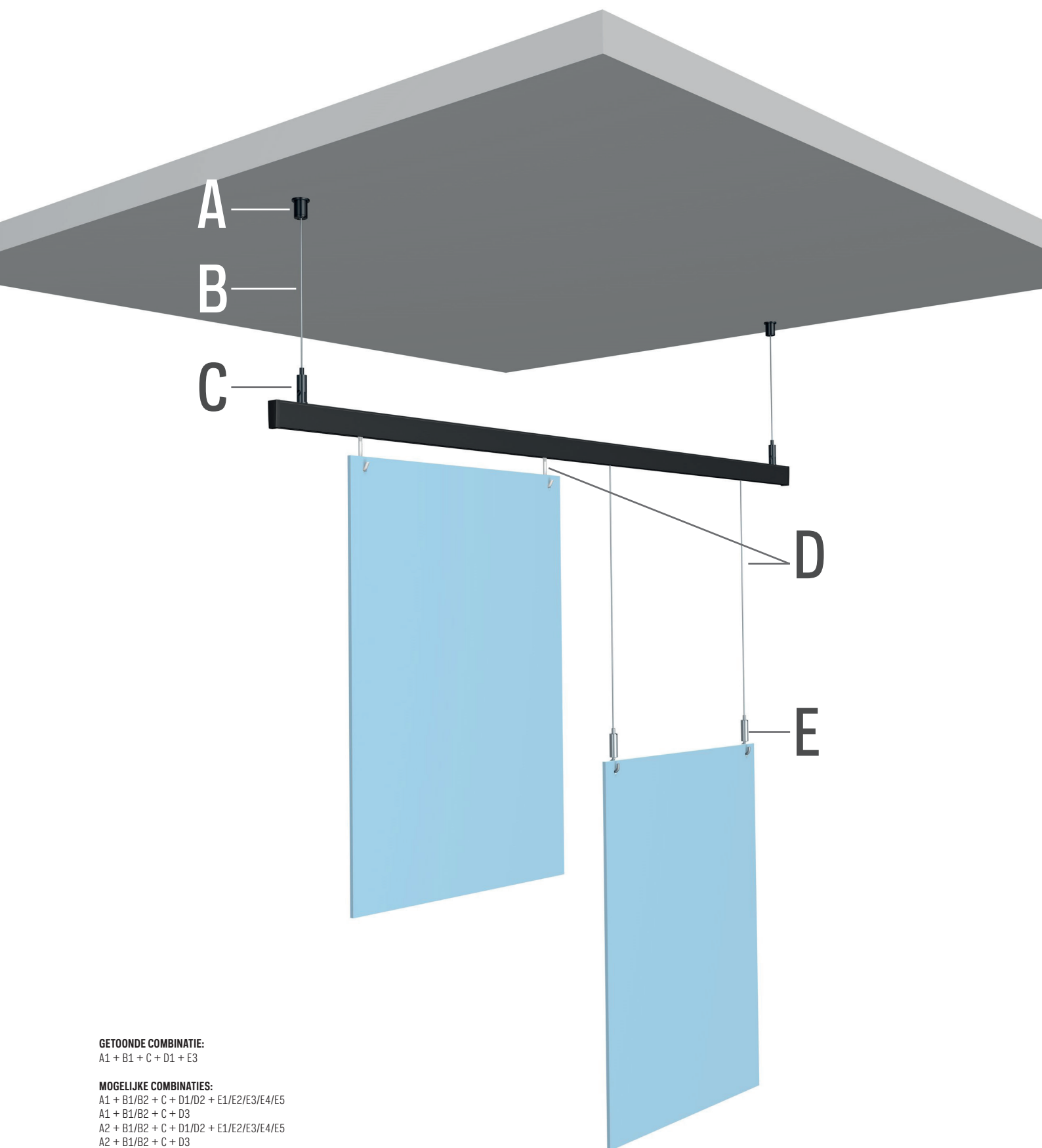

**GETOONDE COMBINATIE:**

A1 + B1 + C + D1 + E3

**MOGELIJKE COMBINATIES:**

A1 + B1/B2 + C + D1/D2 + E1/E2/E3/E4/E5

A1 + B1/B2 + C + D3























A2 + B1/B2 + C + D1/D2 + E1/E2/E3/E4/E5

A2 + B1/B2 + C + D3

A3 + B3 + C + D1/D2 + E1/E2/E3/E4/E5

A3 + B3 + C + D3

# XPO RAIL VERLAAGD HANGEND

<b>A</b>	A1			A2			A3	
								
	PLAFOND-BEVESTIGING ZWART CO1BL	PLUG (Ø 5 mm)	SCHROEF	PLAFOND-BEVESTIGING VERNIKKELD CO1NI	PLUG (Ø 5 mm)	SCHROEF	PLAFONDHANGER ZELFKLEMMEND 1,2 mm CS01NI	
7807.100	9.4931	9.4929	7807.110	9.4931	9.4929	7807.140		
<b>B</b>	B1		B2		B3			
								
	STAALDRAAD + GLIJDER 1,2 mm 200 cm ZWART		STAALDRAAD + GLIJDER 1,2 mm 200 cm VERNIKKELD		STAALDRAAD 7 x 7 1,2 mm 10 m		KABELTANG	
7807.200		7807.210		7807.350		7807.900		
<b>C</b>	C							
								
	OPHANGKLEM XPO RAIL 1,2 mm	XPO RAIL 200 cm ZWART	EINDKAP XPO RAIL ZWART					
7807.060		05.15201	05.15030					
<b>D</b>	D1		D2		D3			
								
	STAALDRAAD + GLIJDER 1,2 mm 200 cm ZWART		STAALDRAAD + GLIJDER 1,2 mm 200 cm VERNIKKELD		TWISTER HAAK			
7807.200		7807.210		9.4510				
<b>E</b>	E1	E2	E3	E4	E5			
								
	STAALDRAADHAAK ZELFKLEMMEND 1,2 mm ST01BL	STAALDRAADHAAK ZELFKLEMMEND 1,2 mm ST01NI	STAALDRAADHAAK ZELFKLEMMEND 1,2 mm ST02NI	STAALDRAADHAAK ZELFKLEMMEND 1,2 mm ST03NI	STAALDRAADKLEMMHAAK ZELFKLEMMEND 1,2 mm STC01NI			
7807.010	7807.020	7807.030	7807.040	7807.050				

SIGNING OPHANGSYSTEMEN

# SIGNING OPHANGSYSTEMEN

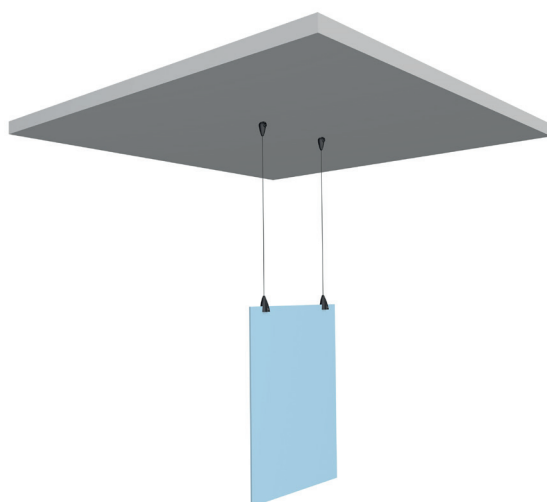
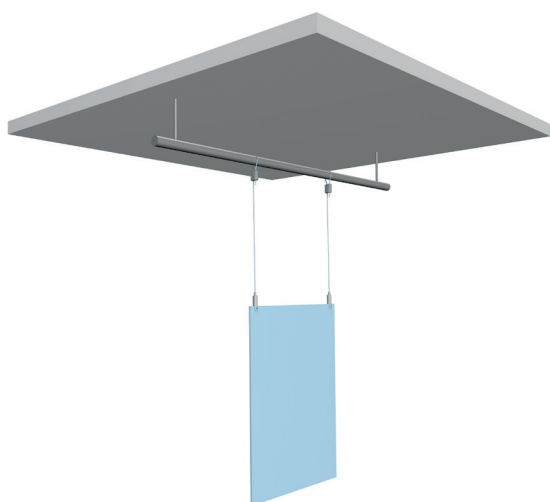
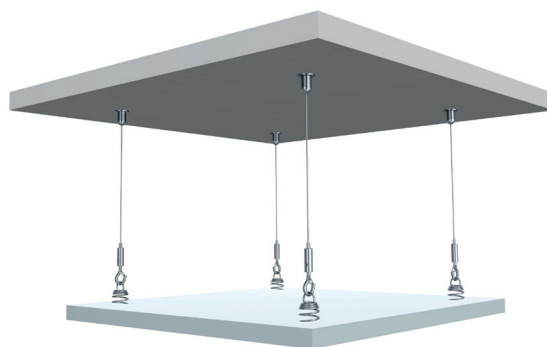
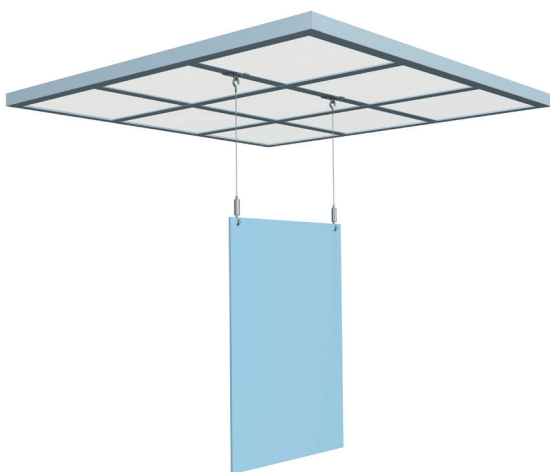
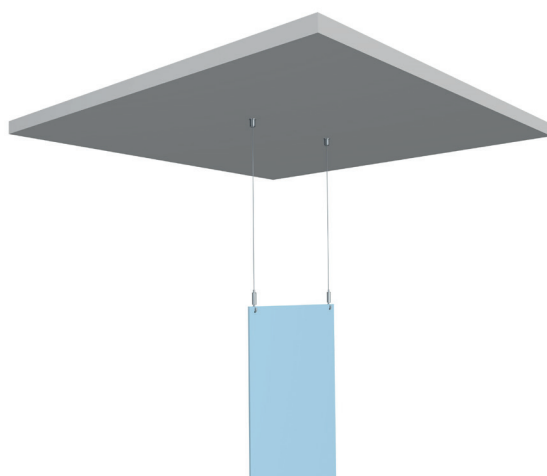
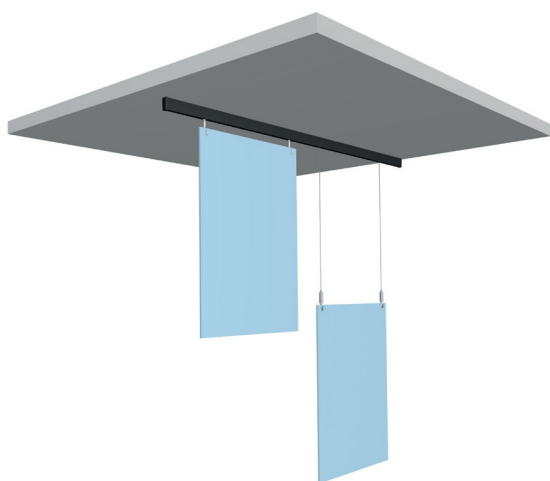

# SIGNING OPHANGSYSTEMEN

Artiteq heeft gekozen voor de Fischer UX 5x30 R plug in combinatie met haar ophangsystemen. De Fischer UX 5x30 R plug is van toepassing op verschillende soorten materialen zoals beton, steen en gipsplaten. Afhankelijk van het materiaal, geldt een maximale belasting voor de plug van **30 kg**. De te gebruiken boor moet een diameter hebben van 5 mm. De plug heeft een lengte van 30 mm. De te gebruiken schroef in combinatie met de plug is 38 mm lang en heeft een diameter van 3,5 mm (te gebruiken in combinatie met een bitje PZ2).

Om de maximale belasting te bepalen van een signing ophangstelsel, is het noodzakelijk om te weten welke bevestigingsmaterialen er worden gebruikt en op welke ondergrond (welk type materiaal) deze worden bevestigd. De onderdelen van het signing ophangstelsel hebben allemaal een maximale draagkracht. Dit is de maximale draagkracht van het onderdeel zelf en niet de maximale draagkracht die in acht genomen moet worden voor het totale systeem. Voor het totale systeem is de belastbaarheid die is afgegeven voor het bevestigingsmateriaal in combinatie met het soort materiaal waaraan het bevestigd is, **leidend**.

Voor elk signing ophangstelsel geldt dat u het gewenste, op te hangen gewicht dient af te stemmen met de maximale belastbaarheid van het bevestigingsmateriaal. Indien systemen worden opgehangen aan andere hangende delen zoals bijvoorbeeld systeemplafonds, dient u de maximale belasting van zo'n hangend deel te weten alvorens onze systemen toe te passen. In de tabellen hieronder vindt u de maximale belastbaarheid voor de Fischer plug in combinatie met verschillende materialen en de maximale draagkracht per onderdeel voor de verschillende signing ophangsystemen.

TYPE		UX 5X 30	
RECOMMENDED LOADS IN THE RESPECTIVE BASE MATERIAL $F_{REC}^{2)}$			
Concrete	$\geq C20/25$	[kN]	0,30
Solid brick	$\geq Mz 12$	[kN]	0,20
Perforated sand-lime brick	$\geq KSL 12$	[kN]	0,30
Vertically perforated brick	$\geq Hlz 12$	[kN]	0,20
Aerated concrete	$\geq AAC 4$	[kN]	0,15
Gypsum plasterboard	12,5 mm	[kN]	0,10
Gypsum plasterboard	25 mm	[kN]	0,10
Gypsum fibreboard	(Fermacell)	[kN]	0,20
Gypsum block	$\rho \geq 0,9 \text{ kg/dm}^3$	[kN]	-



1 Required safety factors are considered.

2 Valid for tensile load, shear load and oblique load under any angle

ART. NR	OMSCHRIJVING	MAX. DRAAGKRACHT
7807.060	Ophangklem Xpo Rail 1,2 mm	15 kg
7807.200	Staaldraad + glijder 1,2 mm 200 cm zwart	15 kg
7807.210	Staaldraad + glijder 1,2 mm 200 cm vernikkeld	15 kg
7807.100	Plafondbevestiging zwart C01BL	15 kg
7807.110	Plafondbevestiging vernikkeld C01NI	15 kg
7807.140	Plafondhanger zelfklemmend 1,2 mm CS01NI	15 kg
7807.350	Staaldraad 7x7 1,2 mm 10 m	15 kg
7805.052	Loop Hanger 1,0 mm - 1,5mm	10 kg
7807.120	Systeemplafondclip 20 mm	5 kg
7807.130	Systeemplafondclip 20 mm + hanger 1,2 mm	5 kg
7807.310	Staaldraad + haak 1,2 mm 300 cm	15 kg
7807.010	Staaldraadhaak zelfklemmend 1,2 mm ST01BL	15 kg
7807.020	Staaldraadhaak zelfklemmend 1,2 mm ST01NI	15 kg
7807.030	Staaldraadhaak zelfklemmend 1,2 mm ST02NI	15 kg
7807.040	Staaldraadhaak zelfklemmend 1,2 mm ST03NI	15 kg
7807.400	Akoestische springveer 01-NI	5 kg
7807.050	Staaldraadklemhaak zelfklemmend 1,2 mm STC01NI	15 kg

# XPO RAIL

# 20 kg/m

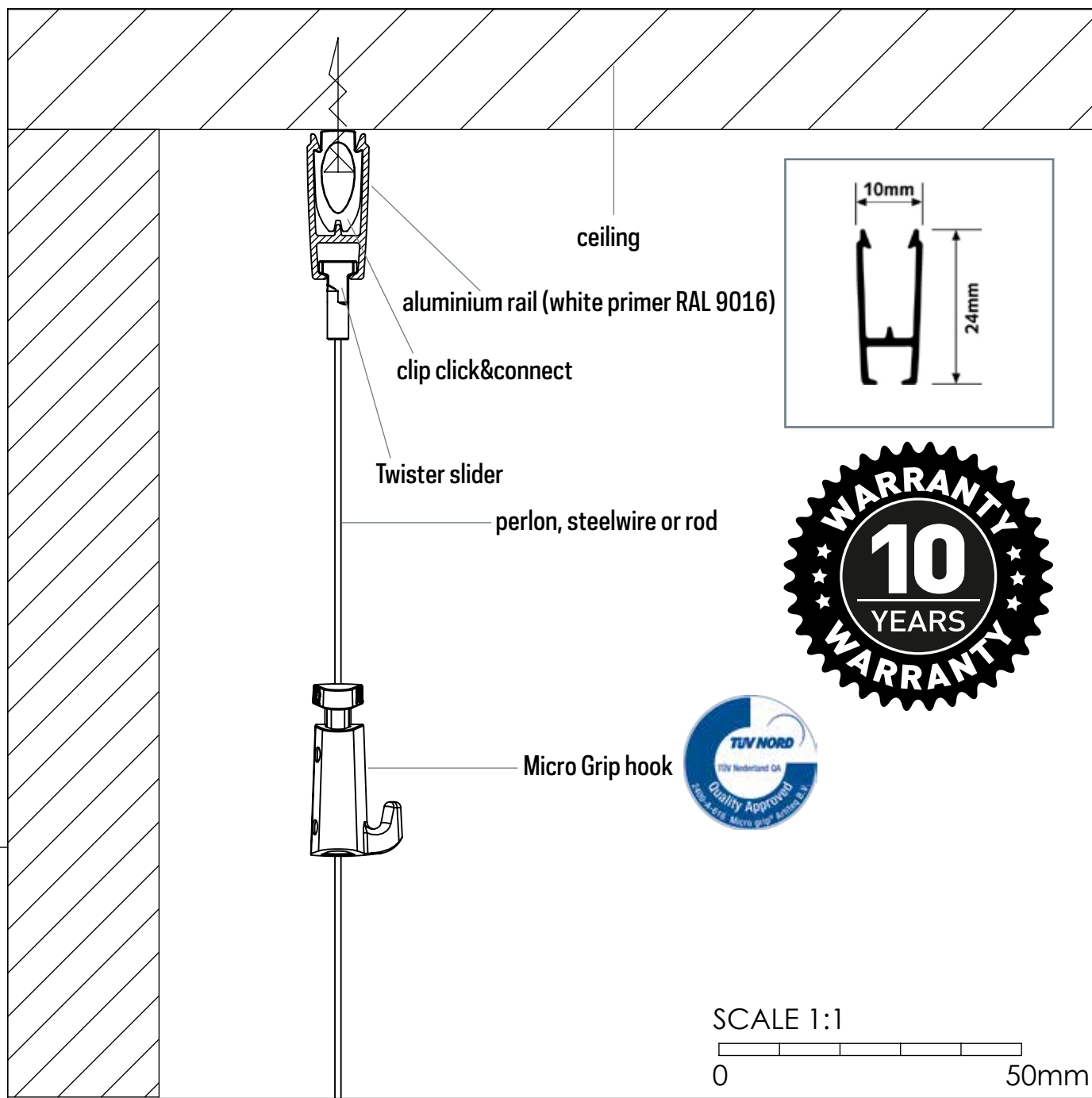

Installation movie:



ARTITEQ  
HERASTRAAT 39  
5047 TX TILBURG (NL)  
T +31 (0)13 572 90 70  
info@artiteq.com

